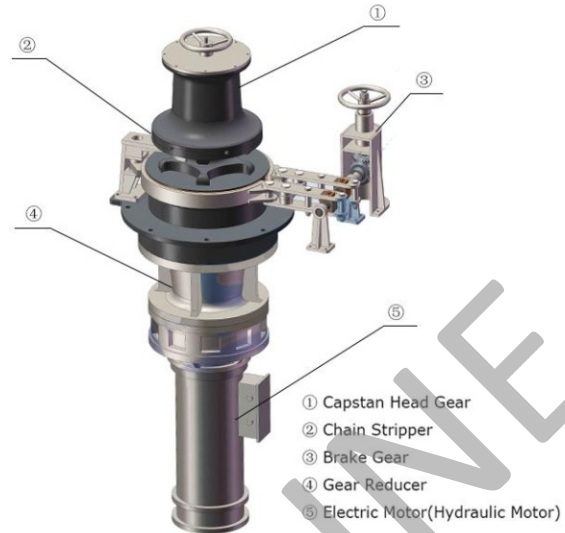

**Advantages**

1. Compact size, small installation space
2. Working smoothly, long working life
3. Overload protection
4. High strength component, durable and reliable
5. Approved by CCS,BV,LR,ABS,DNV-GL...
6. Can be customized as per user's requirements

**Technical Specifications**

- ① Capstan Head Gear
- ② Chain Stripper
- ③ Brake Gear
- ④ Gear Reducer
- ⑤ Electric Motor (Hydraulic Motor)

**Technical Specifications**

Specification	Work load	Anchor speed	Warping load	Warping speed	Motor power
	kN	m/min	kN	m/min	kW
Φ 12.5	6.6	≥9	5	≥9	2.2/0.75
Φ 14	8.3	≥9	6	≥9	2.2/0.75
Φ 16	10.9	≥9	8	≥9	2.2/0.75
Φ 17.5	13.0/14.6	≥9	10	≥9	3/1.3
Φ 19	15.3/17.2	≥9	10	≥9	4.3/1.7
Φ 20.5	17.9/20.0	≥9	15	≥9	4.3/1.7
Φ 22	20.6/23.0	≥9	15	≥9	6/2.5
Φ 24	24.5/27.4	≥9	20	≥9	8.5/3.5
Φ 26	28.7/32.1	≥9	20	≥9	8.5/3.5
Φ 28	33.3/37.2	≥9	25	≥9	8.5/3.5
Φ 30	38.3/42.8	≥9	30	≥9	11/11/7.5
Φ 32	43.5/48.6	≥9	30	≥9	11/11/7.5
Φ 34	49.1/54.9	≥9	40	≥9	16/16/11
Φ 36	55.1/61.6	≥9	40	≥9	16/16/11
Φ 38	61.4/68.9	≥9	50	≥9	16/16/11
Φ 40	68.0/76.0	≥9	60	≥9	22/22/16
Φ 42	75.0/83.8	≥9	60	≥9	22/22/16
Φ 44	82.3/92.0	≥9	70	≥9	22/22/16
Φ 46	89.9/100.5	≥9	80	≥9	30/30/22
Φ 48	97.9/100.5	≥9	80	≥9	30/30/22
Φ 50	106.3/118.8	≥9	90	≥9	30/30/22
Φ 52	114.9/128.4	≥9	100	≥9	30/30/22

Φ 54	123.9/138.5	≥9	100	≥9	45/45/30
Φ 56	133.3/149.0	≥9	120	≥9	45/45/30
Φ 58	143.0/159.8	≥9	120	≥9	45/45/30
Φ 60	153.0/171.0	≥9	140	≥9	45/45/30
Φ 62	163.4/182.6	≥9	150	≥9	45/45/30
Φ 64	174.1/194.6	≥9	160	≥9	60/60/45
Φ 66	185.1/206.9	≥9	160	≥9	60/60/45
Φ 68	196.5/219.5	≥9	180	≥9	60/60/45
Φ 70	208.3/232.8	≥9	200	≥9	60/60/45

Above specifications only for reference, we can supply various capstans according to your requirements.

